



# A Family of Quality

**MASTERCOTE**<sup>®</sup>  
Fluorocarbon Coated  
Bolts & Nuts

**M-RAK**<sup>®</sup>  
Cable Support Systems

**DIMET**<sup>®</sup>  
Cathodic Protection Systems

**TRISTAR**  
Bolting Solutions  
Torqueing Tools & Services

**Pile-Gard**  
Splashzone  
Wrapping System



Valley Forge & Bolt

**MCM**  
MC MILLER Co.  
Cathodic Protection  
Monitoring Equipment

**FSI**  
Flange  
Insulation Kits



## PT. SOUTHERN TRISTAR

Kawasan Jababeka I, Jalan Jababeka III H TOB Block C No 17 J

Cikarang Industrial Estate Bekasi 17550 - Indonesia

Phone : (021) 8935 162, (021) 8984 0238 Fax : (021) 8935 163

Email : sales@ptsts.com

<http://www.ptsts.com>

# Quality Bolting System

## Made to Order Industrial Fasteners, Studs, Anchor bolts, U-bolts, Pipe Clamps, J-Bolts, etc

Comprehensive portfolio of precision engineering studs, U-bolts and J-bolts in sizes from 0.25 to 6 inch diameter, available in both rolled or cut thread. Materials include carbon steel, alloys, stainless steel, galvanized, plated or coated.

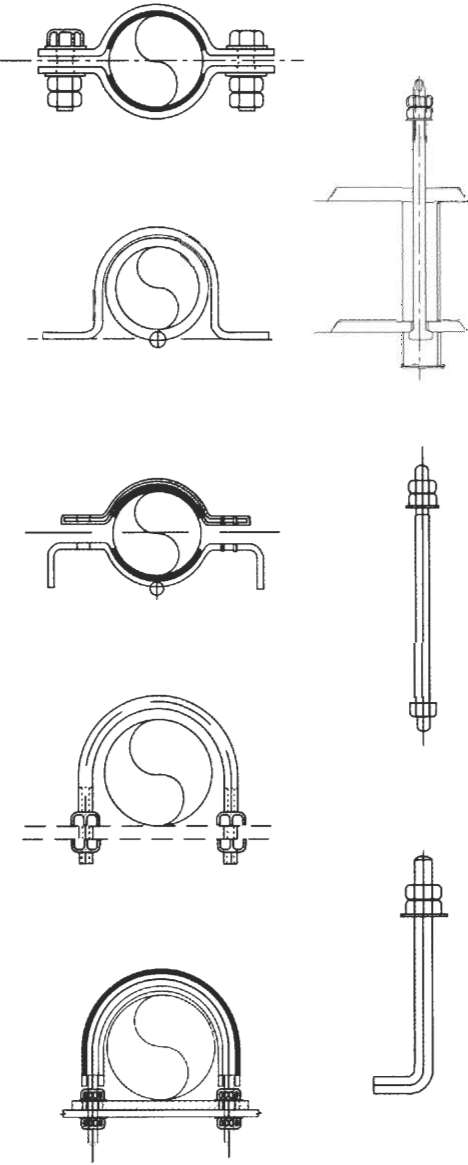

## High Quality Specialty Bolts and Nuts



One end of the studbolt is marked with the relevant material grade symbol

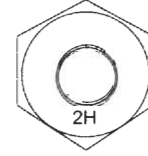

Nut is marked with the relevant material grade symbol  
2H 2HM G4 G7 7M  
8 8M 8MA 8C



### Stocks

ASTM A193 B7 - Imperial sizes 3/8 to 4" dia  
- Metric sizes M12 to M52



ASTM A320 L7 - 1/2" to 4" dia



ASTM A193 B16 - 1/2" to 4" dia



ASTM A193/A320 B8 Class 2 & Class 1 (SS304) 1/2" through to 2-3/4" dia



ASTM A193/A320 B8M Class 2 & Class 1 (SS316) 1/2" to 2-3/4" dia



Stocks come complete with matching nuts



### Manufacturing Process

Studbolts are made from long length of bars. We sell studbolts and nuts plain, Mastercote coated, Cadmium, Zinc, Zinc-Nickel plated, Galvanised or with other types of coating.

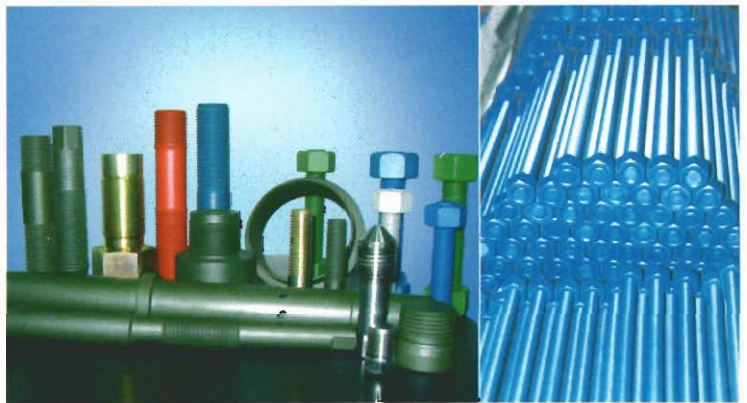

### In-House Furnace

B7M/2HM and L7M/Gr 7M are produced in-house (tested and certified). These are then oiled, grit blasted, plated or Mastercote finished.



### Special Materials available on order

B8T, Titanium, Duplexes, Monel 400, K500, Hastelloy, Incoloy, Inconel, Nimonic, etc.



Bronzes: Phosphor bronze, brass, aluminium, manganese bronze, silicon bronze available on request.

# High Quality Coatings

## MASTERCOTE®

### Fluorocarbon Coated Bolts & Nuts

Mastercote® coating, with high PTFE content and a base metal coat, is best suited for installations in petrochemical plants, offshore platforms and in corrosive environment.

The resin-like bonded coating provides low coefficient friction and excellent resistance to many chemicals and acids. PTFE dry film provides lubricity thus preventing galling in breaking out. Mastercote coated products are the best in the market - salt-fog spray tested to over 9,000 hours without a spot of rust.



Our branded Coated Fasteners include:

- MasterCote • Cadmium based PTFE Top Coat
- MasterGard • Ceramic/Metallic based PTFE Top Coat
- MasterZGard • Zinc Silicate based PTFE Top Coat
- MasterNiZCote • Zinc/Nickel based PTFE Top Coat

### SALT FOG SPRAY TEST - stud bolts subject to 720 hours in a 5% brine spray at 110°F

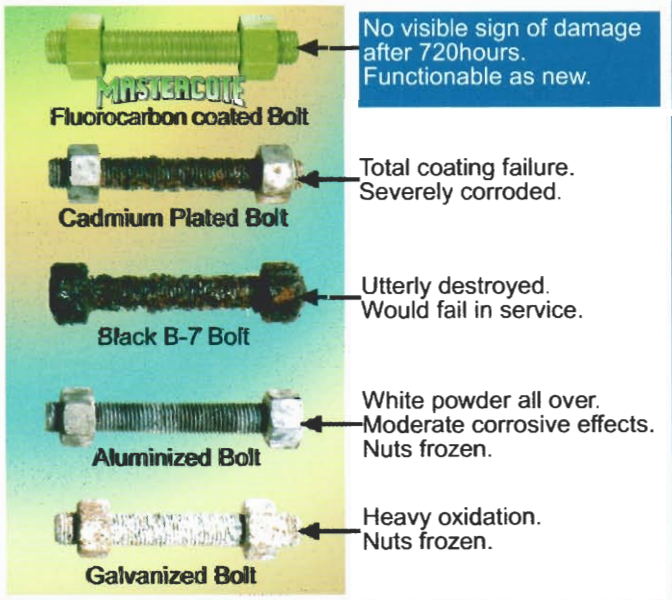

## Xylan®

### Fastener-Class Coatings



Xylan coatings are made of composite materials. Lubricants with the lowest-known coefficient of friction are combined with the newest high-temperature-resistant organic polymers. Together, they form "plastic alloys" with unique properties:

- Low coefficient of friction: as low as 0.02
- Outstanding corrosion and chemical resistance
- Wide operating temperature ranging from -195°C to +285°C
- Pliability: bend freely and repeatedly without breaking
- Machineability: apply multiple coats and mill
- Excellent adhesion to most metals, plastic, ceramics, wood and even to itself.

### TRISTAR Coating Services

We are the approved coater for Whitford, providing electroplating as well as spray coating services, meeting very high quality standards for the oil & gas industries. We are the most reliable coating system provider in the region, showing good anti-corrosion results.



#### TRI-STAR INDUSTRIES PTE LTD

This is to certify that the company listed above has successfully completed Whitford's Quality Approved Coater program in the handling, coating, and testing of Whitford high-performance coatings, thereby qualifying the company as a quality product formulated and manufactured by Whitford and to perform such application from 2014 through 2015.

*Ken Bunn*  
Plant H. Nuts, Managing Director, Asia Region

Whitford

Where good ideas come to the surface.

# Bolt Tensioning



## An Integrated Solution

The bolting services division supplies a full range of bolt working tools and services around the world. We sell, rent and provide service (with technicians) for subsea and topside projects, oil and gas facilities, natural gas processing plant, refineries, petrochemical plants and power stations.



### TRI-STAR Topside and Subsea Tensioners



Tri-Star designs and manufactures its own range of Topside and Subsea Tensioners, ISO 9001 approved.

- Tristar SM submarine bolt tensioners are made from stainless steel material which is corrosion free and therefore, improves durability and reliability.
- Tristar SM tool range of 6 load cells are designed to cover more sizes (3/4" right up to 3-1/2")
- Tristar Flange Puller's improved design with high tensile cable eliminates 'bird nesting'. This problem is commonly found in most flange puller designs. Remote operation with single or multiple operation, individual or simultaneous capabilities.
- Topside MPR Tensioners are flexible with sizes ranging from 5/8" to 4" with 6 primary and 2 secondary tool selections. Metric sizes are available in both SM and MPR tensioners.

Our Critical Joint Integrity Management provides effective controls and systems of operation to ensure leak free startup and operation of joint connections. From manufacture and supply of quality coated studbolts and nuts, to rental of the latest designs of bolt working equipment and provision of on-site services, we offer an integrated service tailored to meet the requirements of your work-scope extending from single connections to full scale construction projects and on-going refinery and plant maintenance contracts.

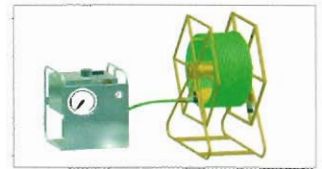

Specialised engineering and design solutions can be tailored to cater for bespoke applications. Applications are provided with latest in-house bolting program designed for comprehensive bolt load data calculation; detailed technical analysis and pump pressure requirements.



ATM Alignment Tool



Torque Wrench Pump



Flange Spreader



Multiplier



### Hydraulic Torque Wrenches

As agents for Torq/Lite®, we offer for sale and rental a full range of Square Drive or Low Profile Hydraulic torque wrenches and power consoles.



IU-XL Series



SU-XL Series



# Cable Support Systems



## Metallic Cable Support Systems



M\*RAK supplied Cable Support Systems to SLNG, Singapore's first LNG terminal



M\*RAK cable ladders installed at one of the jetties at SLNG



Welding robot for efficiency and quality consistency

M\*RAK incorporates several ranges of Cable Support System including ladders, trays, trunkings, wire-mesh trays, channels, concrete inserts, cantilever arms, trapeze, cleats, fasteners and accessories.

There are different ranges to suit the particular engineering needs of customers. The ranges differ in its loading capacity, design, material and finishing. Materials range from stainless steel, carbon steel, electrogalvanized, pre-hot-dipped galvanised, high silicon steel to aluminium and fibre reinforced plastic. Finishings range from hot-dipped galvanised (BS EN ISO 1461:1999), epoxy powder coating to fluoropolymer coating.

## Fibreglass Cable Support Systems

**Best for use in Chemically - Corrosive & Harsh Environment**

- No Earth-Bonding • Easy Installation • Maintenance Free • Corrosion Resistant

### THE PULTRUSION PROCESS

- Available in Polyester, Vinylester, Modar Acrylic Vinylester Resins
- Anti-Static additive is available on request

### TESTS & STANDARDS

- Load tested to NEMA FG-1 up to Class 20C (149kg/M)
- Flame propagation to BS 476 Part 6
- Flame spread to BS 476 Part 7 Class 1 or 2
- UV protection to ASTM G154-06
- Halogen free to IEC 607S4-1
- Impact resistance to D256
- Flame retardancy tested to UI94, V0



# Cathodic Protection



## Cathodic Protection Products & Services



### GALVANIC ANODES

- DIMET aluminium anodes and zinc anodes including:
  - offshore structural anodes (platforms, jetties, wharves, etc)
  - pipeline bracelet anodes (for both onshore and offshore pipelines)
  - marine anodes (for hull, tank, etc)
- DIMET magnesium anodes for onshore underground structures

### IMPRESSED CURRENT ANODES

- Silicon/Chromium/Iron anodes
- Platinised Titanium/Mixed Metal Oxide
- Lead/Silver/Antimony anodes
- Graphite anodes

### TRANSFORMER RECTIFIER

- Custom built cathodic protection transformer rectifiers

### INSTRUMENT

- Copper sulphate, silver chloride, zinc and copper sulphate/zinc reference cell. Distributor for MC Miller's instruments and accessories

The DIMET brand, originating from Australia, has been established in the Cathodic Protection field in Asia since 1970 and is renowned worldwide. The DIMET experience of over 30 years has given us unsurpassed knowledge in the design, manufacture, installation, commissioning and maintenance of the full range of sacrificial anodes, impressed current cathodic protection systems and other corrosion prevention methods.

DIMET brand cathodic protection and corrosion prevention products and services are provided by our cathodic protection teams in Asia-Pacific, together with an extensive group of affiliates in the other parts of the world.

### FIELD SURVEYS

- Soil and water resistivity, PH, Redox potential and pipe to soil potential surveys/measurements
- Offshore platform potential surveys
- Pearson (pipe location) survey, coating inspection
- Corrosion investigations including stray current analysis
- Interference study and mitigation

### DESIGN

- Conceptual or detailed design of Cathodic Protection Systems including material lists, installation drawings and operating instructions

### SUPERVISION

- Field supervision of Cathodic Protection installation by experienced Corrosion Engineers and Technicians

### COMMISSIONING

- Complete commissioning of Cathodic Protection Systems including full report, maintenance instructions and training of site personnel

### MAINTENANCE

- Periodic surveys of existing Cathodic Protection Systems to ensure optimum performance



# Metal Fabrication

## Engineering and Fabrication Works

Metal Fabrication, Machining, Heat Treatment, Plating & Coating.

Fabrication of Skids, Handrails, Pipes, Clamps, Foundation Bolts, Steel Structures, Machined Components serving the Marine, Offshore, Oil & Gas, Petrochemical & Power industries.

We have teams of qualified and experienced welders, metal forming and machining personnel, together with specialized equipment to meet tight manufacturing tolerances.

Welding thickness from 1.2mm to 50mm, with welding specifications AWS D1.6 for stainless steel, including NDT Testing (UT, Lamination Checks, Liquid Penetrant).

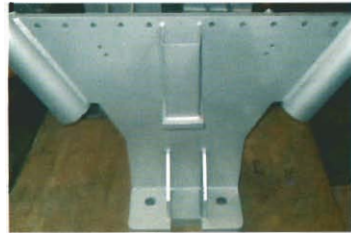

## Agency Products



### Splashzone Wrapping System

PILE-GARD barriers create a tight envelope around the pile isolating the pile from its environment. Oxygen is rapidly depleted from the water in this trapped space and the rate of corrosion is sharply reduced or stopped altogether, depending on the quality of seal obtained. Careful installation techniques will result in a hermetic seal where corrosion cannot continue.



### Flange Insulation Kits and Monolithic Joints

Flange insulation kits are available for all flange sizes, types, pressure ratings and materials. Each kit is individually and securely packed and clearly labelled for convenience in warehousing and field use.

#### ELECTROSTOP™ WELD-IN ISOLATING FITTINGS

Bolt sleeves and washers - the major source of short circuits in most isolation assemblies are eliminated with the Electrostop™.





## Our Quality Testing Facilities



Profile Projector



Tensile Strength Tester



Eddy Current Tester

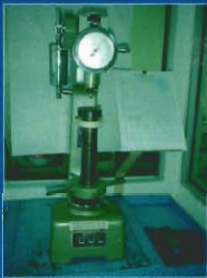

Hardness Tester



EC Test



Spectrometer



Charpy Tester



Microscopic Analyser



Salt Spray Tester

## International Presence

**INDONESIA FACTORY**  
**PT SOUTHERN TRISTAR**  
JAKARTA FACTORY  
Tel (62 21) 893 5162  
Fax (62 21) 893 5163  
Email sales@ptsts.com

**BATAM FACTORY**  
Tel (62 778) 748 2263  
Fax (62 778) 748 2262  
Email batamsales@ptsts.com

**Associated Companies**  
**TRI-STAR INDUSTRIES PTE LTD**  
36 Joo Koon Road, Singapore 628988  
Tel (65) 6266 3636  
Fax (65) 6265 3635 / 6265 2801  
Email sales@tristar.com.sg  
Web www.tristar.com.sg

**SBN INDUSTRIES SDN BHD**  
**Malaysia**  
**JOHAR FACTORY**  
Tel (607) 388 2521  
Fax (607) 388 2523  
Email sales@sbnbiz.com  
Web www.sbnbiz.com

**KL OFFICE**  
Tel (603) 21816341 / 6342 / 6334 / 6337  
Fax (603) 2181 6335  
Email sbnkl@sbnbiz.com

**SARAWAK OFFICE**  
Tel (608) 565 1600  
Fax (608) 565 7180  
Email sbnmiri@sbnbiz.com

**TRENGGANU OFFICE**  
Tel (609) 859 7600  
Fax (609) 859 7701  
Email sbnkmm@sbnbiz.com

**TRISTAR INDUSTRIES (SHANGHAI) CO., LTD**  
**SHANGHAI FACTORY**  
Tel (86 21) 5727 7070  
Fax (86 21) 5727 1165  
Email sales@tristar-cn.com

**TRISTAR MIDDLE EAST INDUSTRIES LLC**  
**DUBAI FACTORY**  
Tel 971 (4) 8847 707  
Fax 971 (4) 8847 709  
Email sales@tristar-mideast.com

**TRI-STAR AUSTRALIA PTY LTD**  
**PERTH FACTORY**  
Tel (61) 8 9494 2151  
Fax (61) 8 9434 9206  
Email sales@tristar-au.com

**LINUS PRODUCTS INC**  
**HOUSTON DISTRIBUTION CENTRE**  
Tel (1 713) 466 6466  
Fax (1 713) 466 1814  
Email sales@linusproducts.com

